

single-band ssb transceiver

using the LM373 communications IC

How to use
the versatile LM373
and several other ICs
to build
a compact
ssb transceiver
for 14 MHz

Charles H. Hill, W5BAA, 2510 Beatty, Houston, Texas 77023

About two years ago a new products announcement in *ham radio* described a linear communications IC, the National Semiconductor LM373. Although I have found the LM373 to be the most versatile IC for the communications field on the market, I have not seen any articles in the amateur publications which have given the LM373 the praise which I feel it deserves.

One of the strongest assets concerning the device is the very comprehensive data which the National Semiconductor Corporation supplies on request. With this data you can use the IC in a variety of signal processing roles with a minimum of brain work. In order to sing the praises of the device, I will describe a 20-meter QRP ssb transceiver which I have built around the LM373. Although sufficient information is provided in this article so that you may homebrew your own version, I would strongly suggest that you obtain the data sheets on the IC from National Semiconductor in order that you may fully appreciate the versatility of the device.*

communications IC

Fig. 1 is a functional outline of the LM373. National bills the device as an a-m/fm/ssb i-f strip; however, it is used for a host of other functions including dsb generators and receiver frontends. The package includes an agc-controlled gain stage, the output of which may be used to drive a crystal, mechanical or LC filter; a fixed-gain stage, which may be

transceiver

In the transceiver a common i-f strip is built using U1, an LM373 (see fig. 2). By switching the input signal applied to pin 2 from the output of the receiver frontend to the output of the dsb generator, the local oscillator signal at pin 6 from the 9-MHz bfo to the 5-MHz vfo, and the output at pin 7 from the audio amp to the 14-MHz filter, one LM373 IC acts as a

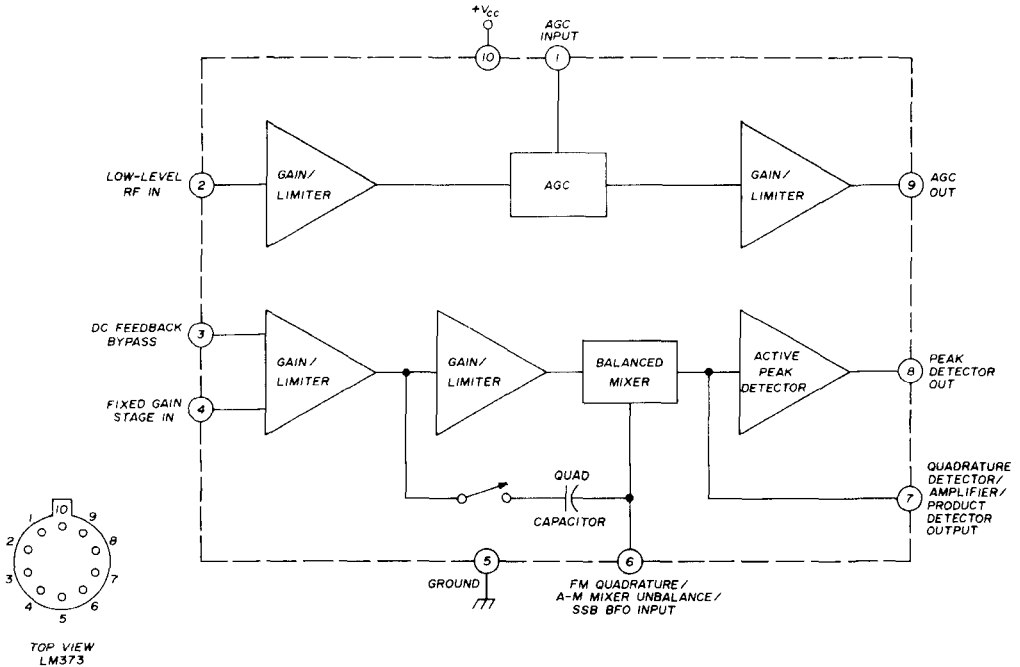

fig. 1. Block diagram of the versatile National Semiconductor LM373 communications IC. This IC can be used in a number of communications circuits, as illustrated in the 14-MHz transceiver circuit shown in fig. 3.

driven by one of the forementioned filters; a balanced mixer driven by the fixed gain stage and an agc generator which is matched to the agc controlled stage. In addition to the access points for the filter terminations, access is provided for nulling both the signal and local oscillator ports of the balanced mixer.

*National Semiconductor Corporation, 2975 San Ysidro Way, Santa Clara, California 95051.

both a receiver i-f strip with a built-in product detector and agc system, and transmitter filter and hf mixer with a built-in agc controlled speech compression. Of course, a 9-MHz ssb filter, FL1, placed between pins 9 and 4 provides the necessary filtering. All of the switching is handled by diode signal switches.

In addition to i-f duties, the LM373 is also used as a dsb generator. In this case the output of a dynamic microphone is fed directly to pin 4 of U2, the fixed gain

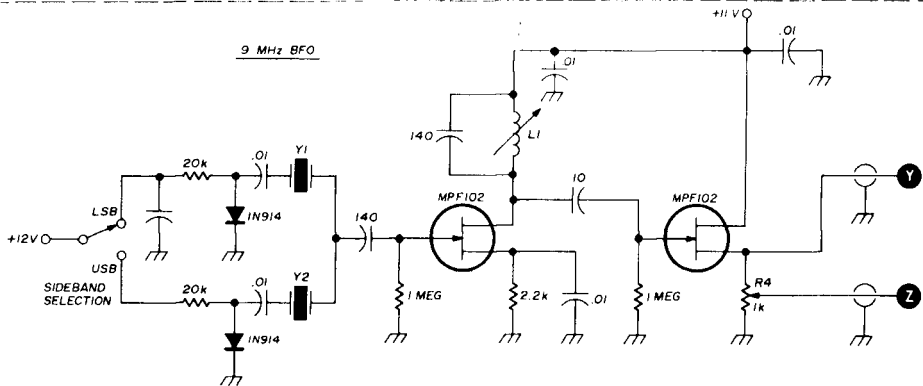
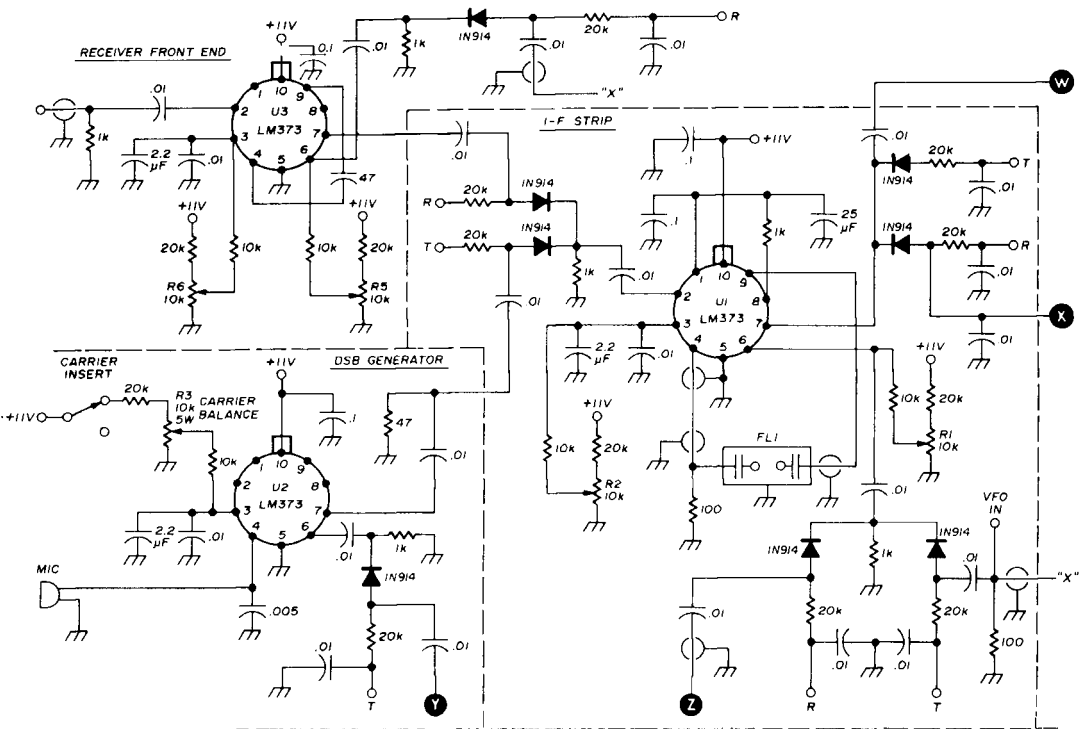

- FL1 9-MHz crystal filter (KVG)
- FL2 Primary, 3 turns no. 26; tuned winding, 26 turns no. 26 on Amidon T-25 SF toroid core
- L1 24 turns no. 26, spacedwound to cover entire length of Miller 4300-2 slug-tuned, ceramic coil form
- Y1,Y2 Upper and lower sideband crystals for 9-MHz crystal filter (KVG)

fig. 2. Circuit diagram for the complete 14-MHz CW/ssb transceiver based on the National Semiconductor LM373 communications IC.

stage input. The 9-MHz bfo signal is switched to pin 6 during transmit, and the dsb output is taken at pin 7.

In the transceiver an LM373 is also used as a receiver front end. The input

signal is applied to pin 2 of U3, and a 47-pF capacitor couples the output of the agc controlled gain stage (pin 9) to the input of the fixed gain stage (pin 4). The 5-MHz vfo is switched to pin 6 during

circuit shown is taken directly from Motorola application notes.

The 14-MHz ssb signal from the i-f strip is separated from the 4-MHz product by the 14-MHz filter, FL2. This resonant circuit is tuned by a Motorola Epicap, MV2209. This allows the driver tune control, a variable resistor, to be remotely mounted on the front panel. An fet drain follower provides a low impedance output from the tuned circuit to the input of the linear amp. The first stage of the linear amplifier is an RCA CA3028A IC in a differential amplifier configuration which drives two 2N2102 emitter followers. These, in turn, drive two 2N2102 transistors in push pull. The final consists of two 2N3553 transistors in class B push pull. The output is transferred by transformer T2 through a coax relay to the 14-MHz input/output filter. This filter serves as both an output filter for the transmitter and an input filter for the receiver.

construction

The transceiver is built on a single piece of copper clad epoxy board with the 5-MHz vfo and linear amplifier mounted separately. The copper is left on to provide the necessary ground plane. Holes are drilled with a no. 60 drill to allow component leads to pass through the board. Ground connections are made directly by soldering to the copper foil. Leads above ground are isolated by reaming away the copper around the holes. The component leads are then hard wired on the non-copper side of the board. All capacitors are rated for 15 volts dc and all resistors are 1/4 watt. All diodes except the Epicap are 1N914 switching diodes. The ssb filter and matching crystals are manufactured by KVG. The only shielding required is around the 9-MHz bfo, around the vfo and between stages of the linear amplifier.

The layout I used is shown in the photograph. An exact layout is not provided here because the actual components I used may be unavailable to you, or may vary somewhat in size. To produce a

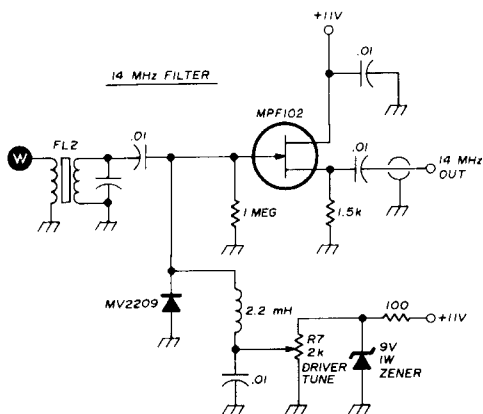

AUDIO AMPLIFIER

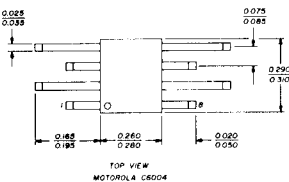
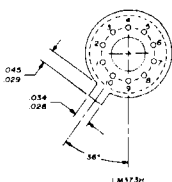
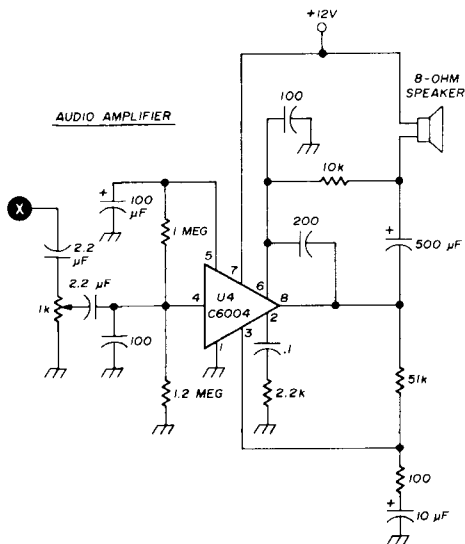

receive, and the frontend output is taken from pin 7. All of these LM373 circuits are taken directly from the National Semiconductor application notes.

Audio amplification is provided by the Motorola C6004, U4, which is capable of producing a 1-watt output into an 8-ohm speaker without any transformers. The

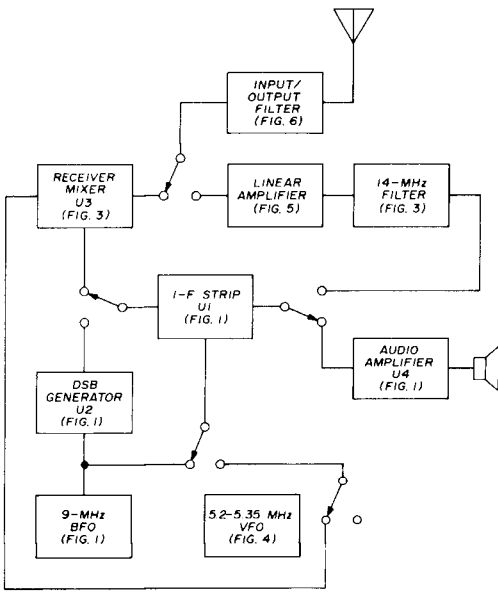

fig. 3. Block diagram of the 14-MHz transceiver in the receive mode. Complete diagram of the transceiver is given in fig. 2.

drilling template, I used ten-squares-per-inch grid paper on which to lay out the components to actual size. It is wise to make all leads as short as possible, and to use shielded lead where indicated in the diagrams. A rigid mechanical frame will insure adequate frequency stability.

tuneup

Since I have a limited amount of test equipment (5-MHz oscilloscope, a Q meter and a crystal calibrator) I had to use a boot-strap method to align the unit. First,

check the audio amplifier by touching pin 4 of the C6004 IC with a metal screw driver. The 60-Hz pickup should drive the audio amplifier to good audio output.

Next, the 9-MHz crystal bfo may be brought to life by monitoring its output with an oscilloscope (I am able to see the signal on my 5 MHz scope) or listening to the audio output for a rush of noise while adjusting inductor L1. The i-f strip may be aligned by switching the carrier insert switch to the carrier on position, the unit to transmit, and observing the output of U1 at pin 7 with the scope while adjusting R1 (the signal port null) for a maximum signal output.

Also, it will be necessary to adjust the local-oscillator port null, R2, but first it is necessary to null the carrier from the dsb generator. This is done by switching the carrier insert switch to carrier off and adjusting R3 for a null as observed at pin 7 of U1. Resistor R4 must be adjusted to a threshold point where the null is minimum. Now the i-f local oscillator port may be nulled by adjusting R2 for a null as observed at pin 7 of U1.

Since the signal port adjustment will interact with the local oscillator port null, R1, R2 and R3 must be adjusted in sequence several times to achieve maximum signal output at pin 7 with the carrier on, and for minimum signal with the carrier off.

At this point the i-f strip and the dsb generator are aligned. The receiver front-end may be aligned with or without a signal generator. To align the circuit with

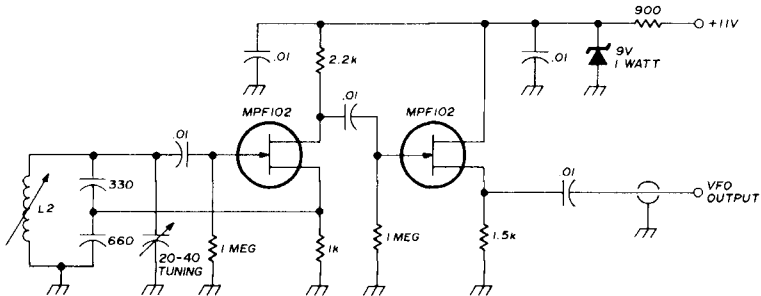
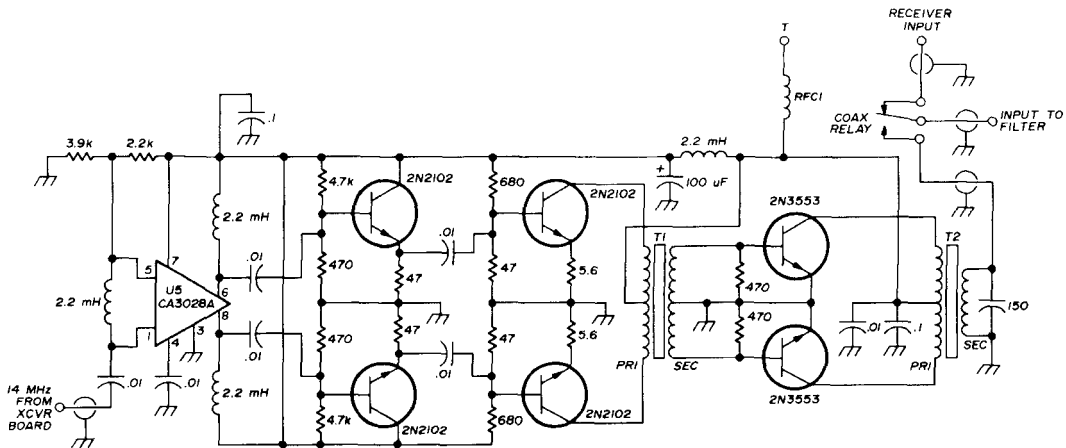

fig. 4. Vfo for the 14-MHz transceiver shown in fig. 3 covers the range from 5.2 to 5.35 MHz. All fixed capacitors are silver-mica units. Inductor L2 is 35 turns no. 26, scramble wound over one-half the length of a Miller 4300-2 ceramic coil form.



- RFC1 25 turns no. 16 on Amidon T-50 SF toroid core
- T1 Primary, 20 bifilar turns no. 26; secondary, 6 bifilar turns no. 26 on Amidon T-37 SF toroid core
- T2 Primary, 18 bifilar turns no. 26; secondary, 26 turns on Amidon T-68 SF toroid core

fig. 5. Solid-state linear amplifier provides up to 5 watts output at 14 MHz.

a signal generator, feed the 14-MHz generator output into the antenna terminal and tune L2 until a signal is heard. Next, adjust the signal port null control, R5, for a maximum signal as observed at pin 7 of U1. Also, check for peak tuning of the input/output filter by adjusting C1 for maximum signal at pin 7. If a signal generator is not available, attach an antenna during daylight hours and tune L2 until 20-meter signals can be heard, then adjust R5 and C1 as described above. Now the local oscillator port may be nulled by removing the antenna or signal generator and adjusting R6 for minimum signal at pin 9 of U1. This concludes the receiver frontend alignment.

The linear is a wideband amplifier and requires no alignment. However, if trouble is experienced, bypass the 14-MHz filter and feed the signal from pin 7 of U1 directly into the linear amplifier. This signal will contain a 4-MHz component which can be detected by the scope, thus facilitating normal amplifier troubleshooting procedures. To peak the signals into and out of the linear amplifier, adjust R7, the 14-MHz filter tuning, and C1, the input/output filter tuning, for a maximum signal as indicated

on the output meter. This should be done with a 50-ohm antenna or a 50-ohm dummy load attached to the antenna terminal, and the carrier insert switch in the carrier *on* position.

When you have reached this point you can calibrate the transceiver by whatever means available and try it out on the air.

performance

With only 5 watts PEP output a little operator skill is required to communicate.

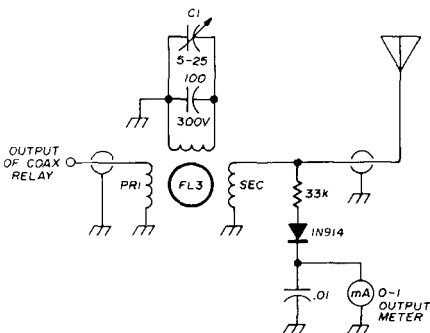

- FL3 Primary, 3 turns no. 16; secondary, 2 turns no. 16; tuned winding, 16 turns no. 16, all on Amidon T-50 SF toroid core

fig. 6. Input/output filter for the 14-MHz CW/ssb transceiver.

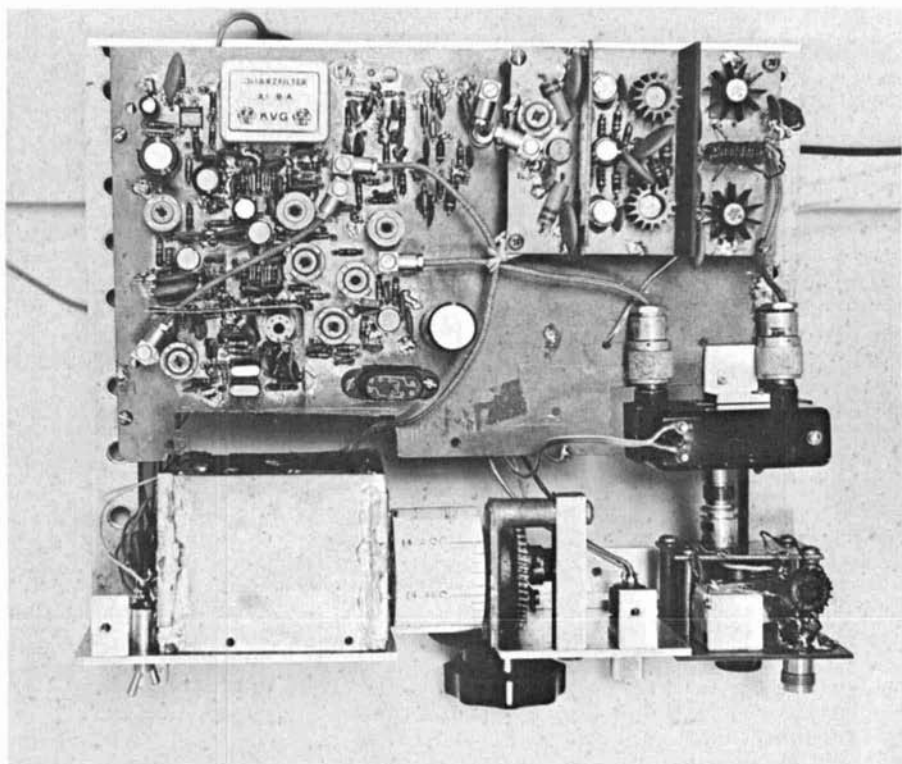

Layout of the 14-MHz transceiver, showing the location of the major components.

However, I never cease to be thrilled to announce that I am using QRP after receiving a good signal report. Always get a signal report before telling the other fellow that you are QRP — by some strange phenomenon my signal always goes down after announcing my power level. I must admit that several unsolicited compliments of the audio quality have been made which I attribute to the agc action of U1 during transmit.

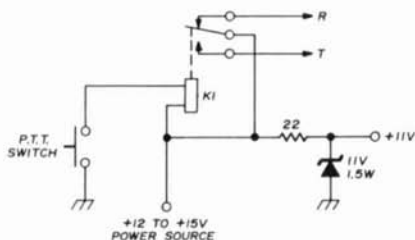

fig. 7. Dc power switching for receive/transmit control on the 14-MHz transceiver.

refinements

If you want to add 75-meter operation, a 4-MHz filter could be switched into the signal path between U1 and the linear amplifier, and a 4-MHz input/output filter switched in between the coax relay and the antenna. Also, a trimmer capacitor would have to be switched into the vfo tank circuit to obtain proper frequency coverage.

The fet oscillator circuits could be replaced by the National LM375 IC, which is a linear IC designed for oscillator/buffer duties. If more power output is desired, a linear amplifier built around the Motorola 2N6367 or 2N6368 might be considered. These transistors are silicon npn devices designed especially for hf ssb service. Motorola provides very good information on the use of these devices from 4 to 30 MHz.

ham radio